

[ BASE & FLANGE ]

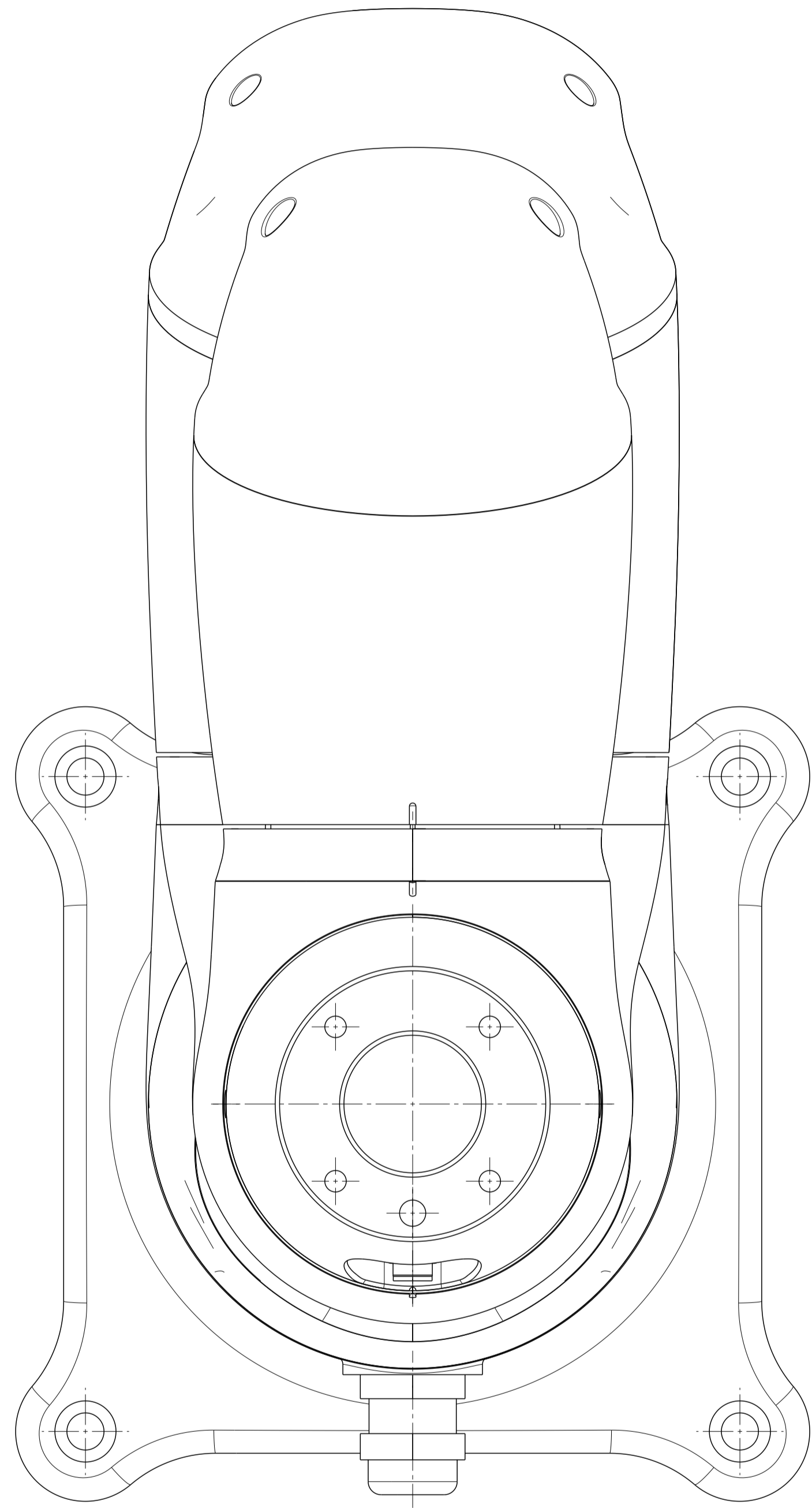

**TOP VIEW (1:1)**

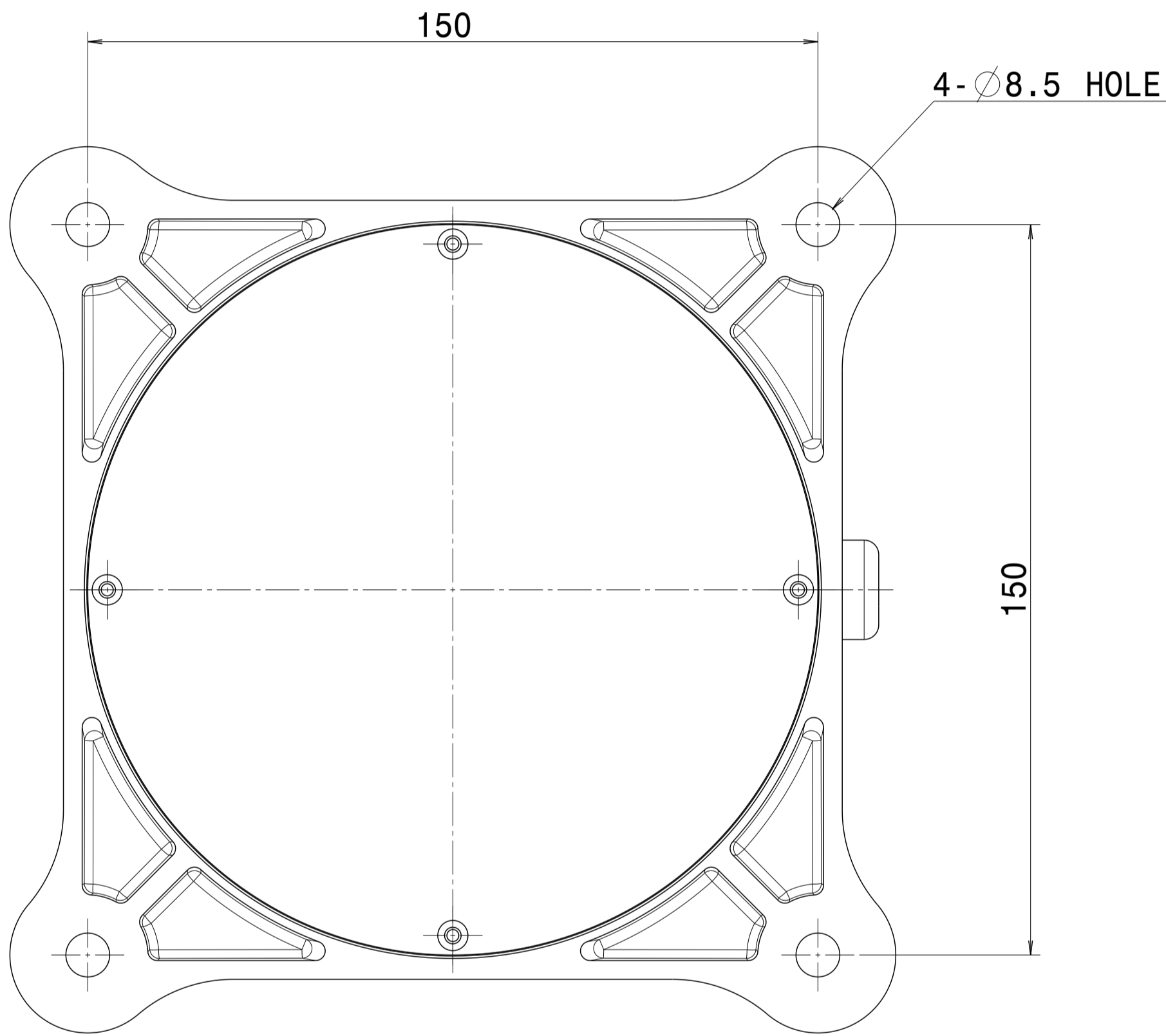

**BASE (BOTTOM VIEW)  
(1:1)**

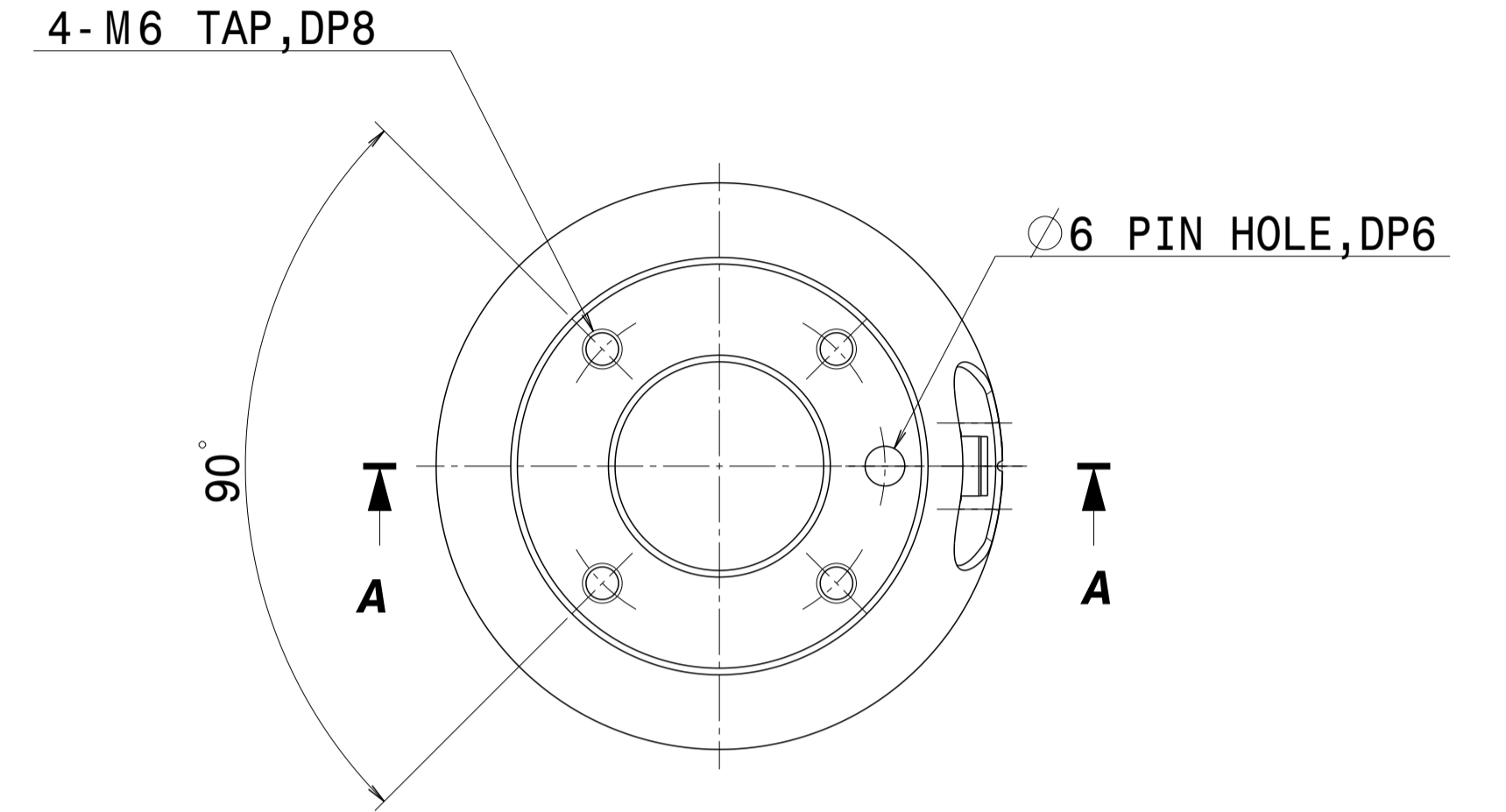

**END FLANGE  
(1:1)**

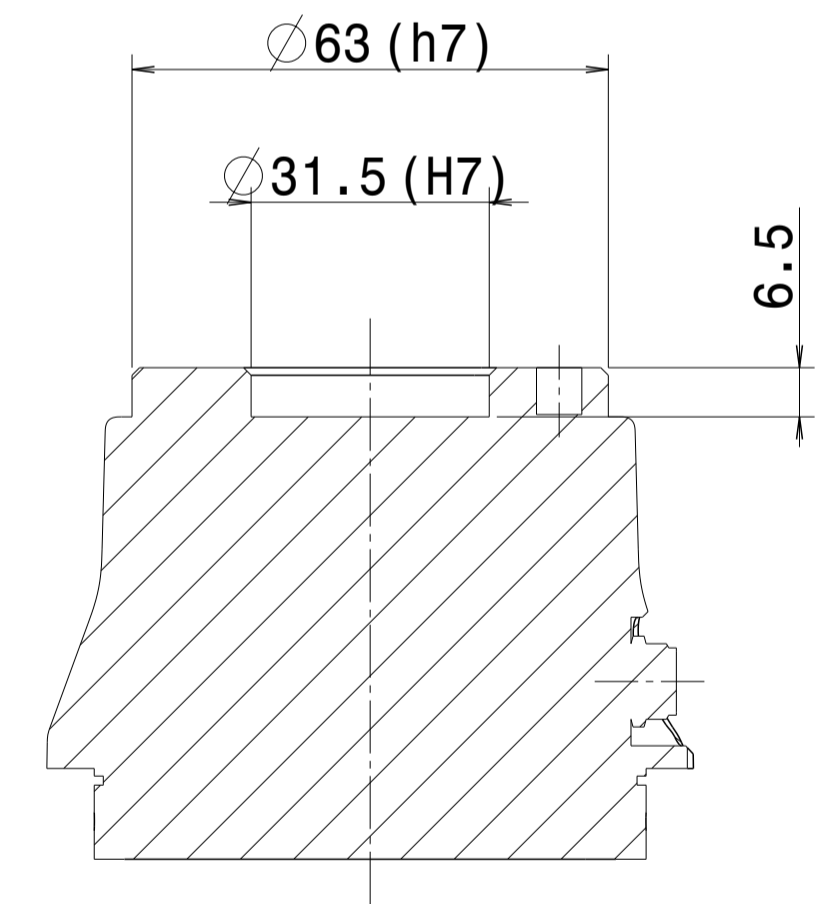

**SECTION VIEW A-A (1:1)**

SUFFIX	MARK	SUBJECT	ECN. NO.	DATE	NAME	CHECKED
	△ X					
	△ X					
	△ X					

SURFACE FINISH		APPROVED		TITLE		Q'TY		1	
GENERAL TOLERANCE (MACHINING)		CHECKED		ASS'Y		A0509 LAYOUT		W.T (KG)	
OVER	TO	GENERAL CHAMFERS		MODEL		MAT.		SCALE	
6	30	HEAT TREATMENT HARDNESS		DRG. NO.		A1		1/1	
30	120	HEAT TREATMENT METHOD		REF. DRG. NO.					
120	315	SURFACE TREATMENT		DRAWN		20.06.10			
315	1000								
1000	2000								
2000	4000								

**DOOSAN**