

[ WORKING SPACE ]

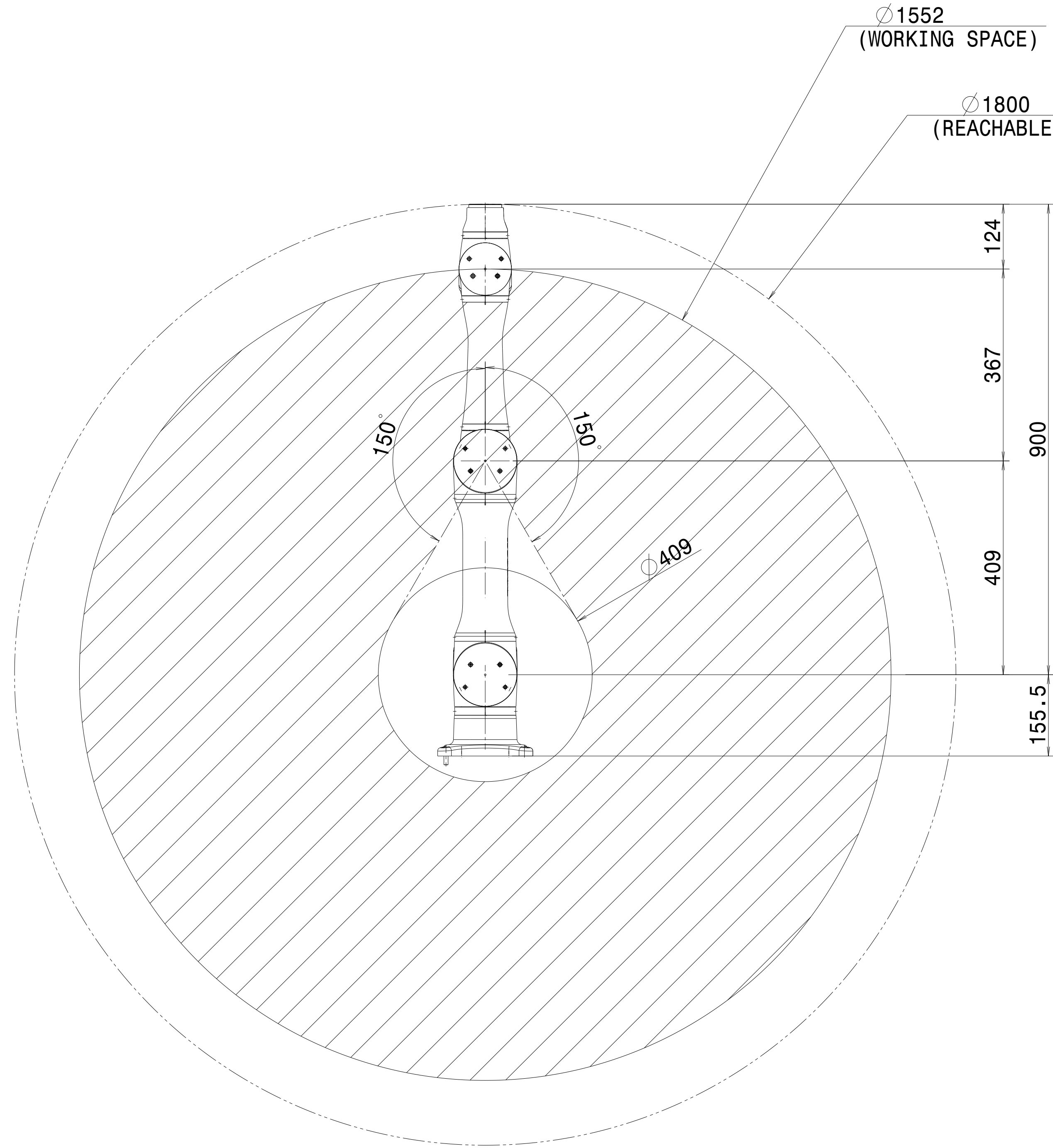

**FRONT VIEW (1:6)**

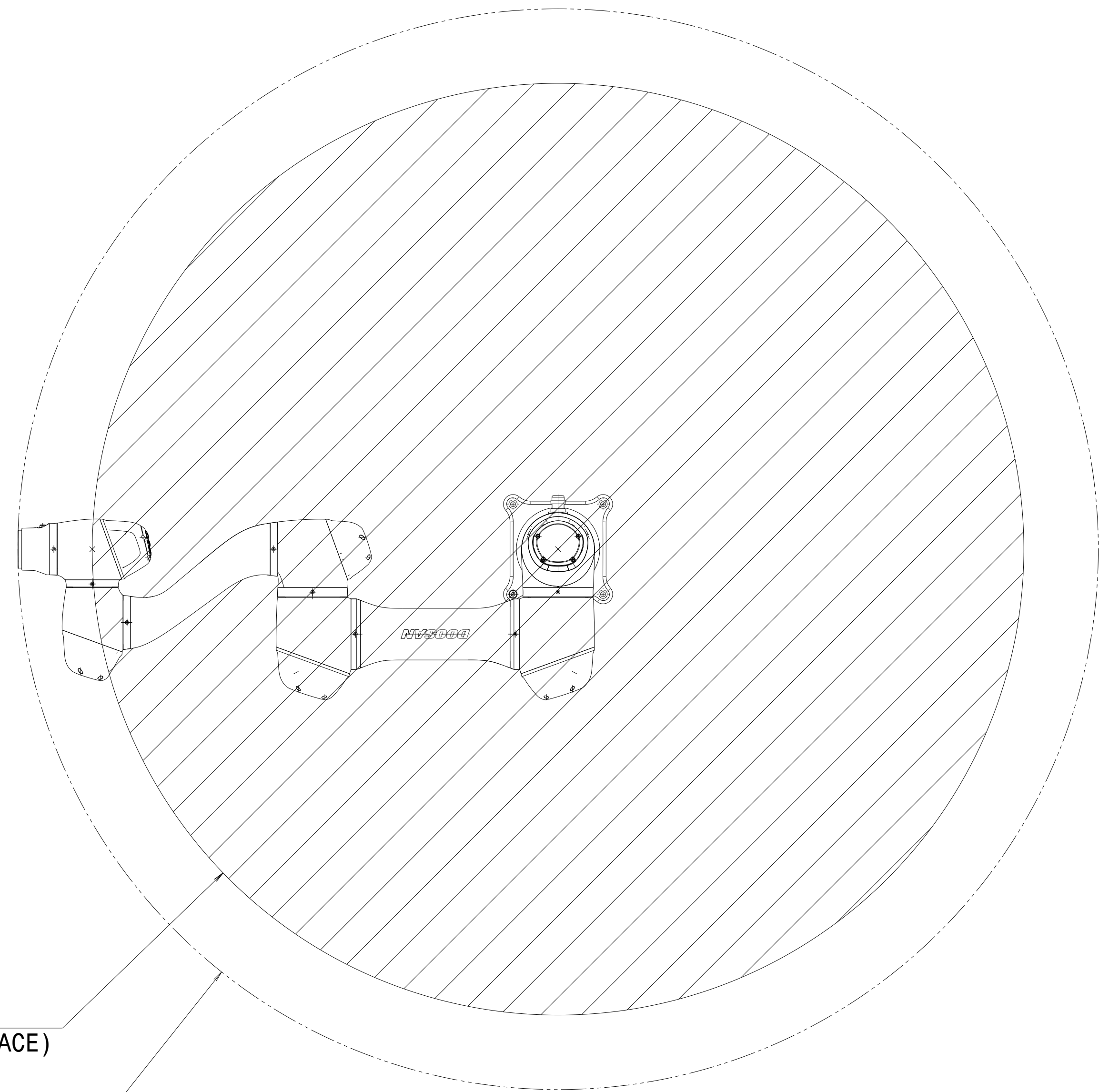

**SIDE VIEW (1:6)**

JOINT RANGE	
AXIS	WORKING AREA(SOFTWARE LIMIT) /DEGREE
1	-360 ~ 360
2	-360 ~ 360
3	-150 ~ 150
4	-360 ~ 360
5	-360 ~ 360
6	-360 ~ 360
PAYLOAD	5kg
REACH	900mm

SUFFIX	MARK	SUBJECT	ECN. NO.	DATE	NAME	CHECKED
	△ X					
	△ X					
	△ X					

SURFACE FINISH		APPROVED		TITLE		Q'TY	
GENERAL TOLERANCE (MACHINING)		CHECKED		A0509 LAYOUT		1	
OVER TO		GENERAL CHAMFERS		ASS'Y		W.T (KG)	
- 6	+0.1	HEAT TREATMENT		MODEL		SCALE	
6 - 30	+0.2	HARDNESS		MAT.		1/1	
30 - 120	+0.3	HEAT TREATMENT METHOD		DRG. NO.		1/1	
120 - 315	+0.5	SURFACE TREATMENT		REF. DRG. NO.		A1	
315 - 1000	+0.8	DRAWN		20.06.10		DOOSAN	
1000 - 2000	+1.2						
2000 - 4000	±2.0						