

[WORKING SPACE]

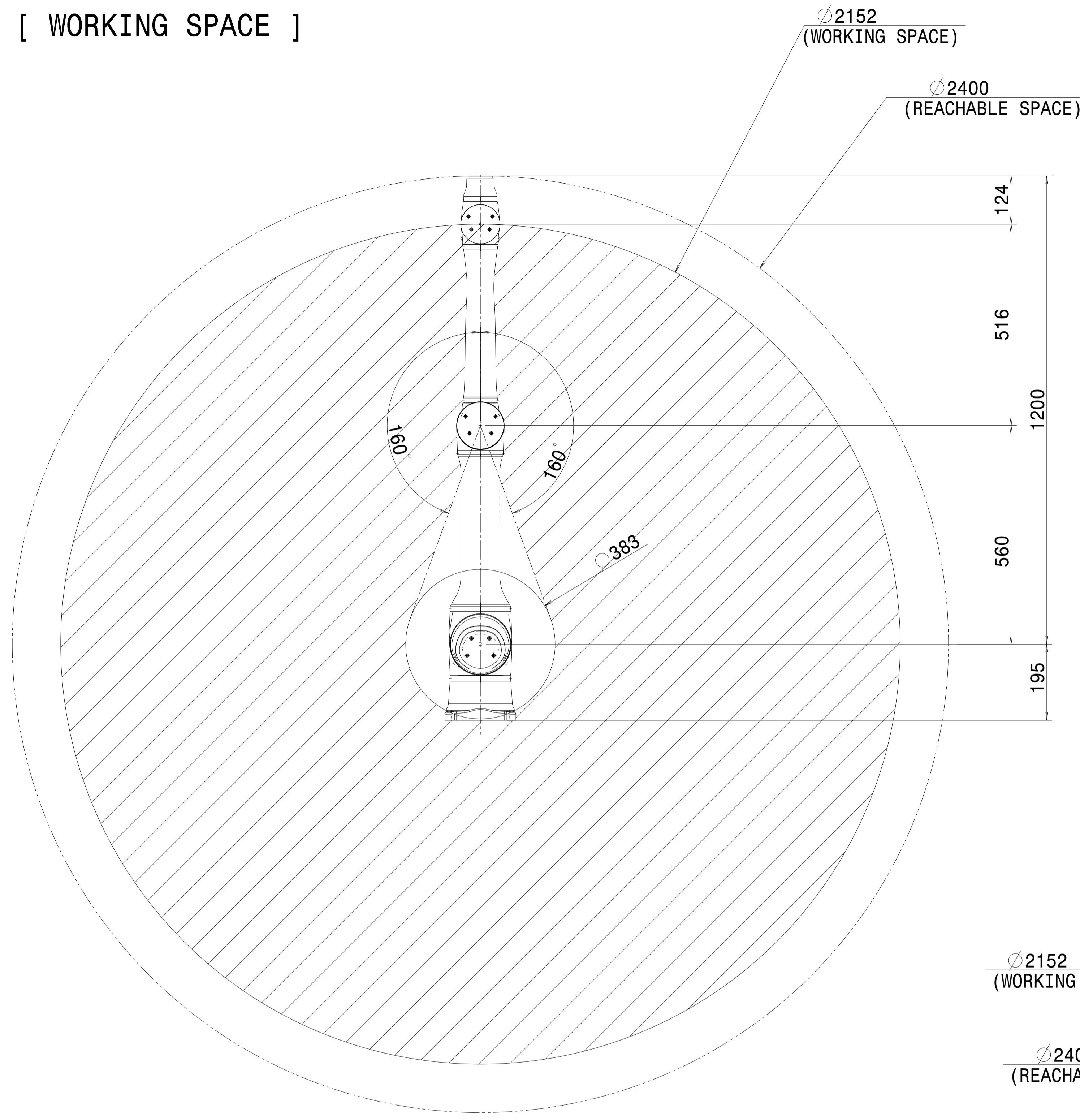

FRONT VIEW (1:7)

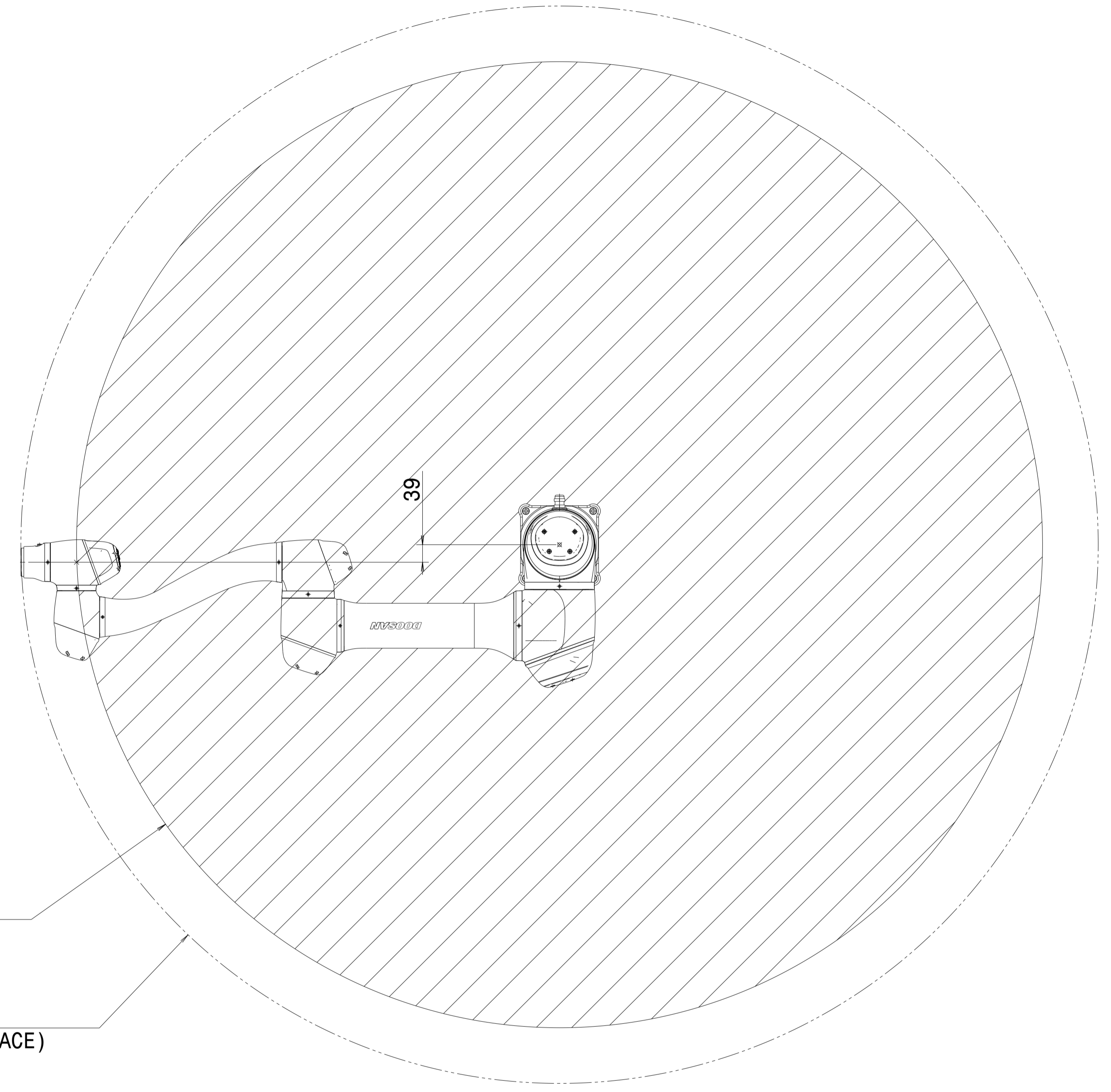

SIDE VIEW (1:7)

JOINT RANGE	
AXIS	WORKING AREA (SOFTWARE LIMIT) / DEGREE
1	-360 ~ 360
2	-360 ~ 360
3	-160 ~ 160
4	-360 ~ 360
5	-360 ~ 360
6	-360 ~ 360
PAYLOAD	9kg
REACH	1200mm

SUFFIX	MARK	SUBJECT	ECN. NO.	DATE	NAME	CHECKED
	△ X					
	△ X					
	△ X					

SURFACE FINISH		APPROVED		TITLE		Q'TY		1	
GENERAL TOLERANCE (MACHINING)		CHECKED		ASS'Y		W.T (KG)			
OVER	TO	GENERAL CHAMFERS		MODEL		MAT.		SCALE	
- 6	+0.1	HEAT TREATMENT HARDNESS		REF. DRG. NO.		A1		1/1	
6 - 30	+0.2	HEAT TREATMENT METHOD		DRAWN		20.06.10		DOOSAN	
30 - 120	+0.3	SURFACE TREATMENT		DATE					
120 - 315	+0.5			NAME					
315 - 1000	+0.8			CHECKED					
1000 - 2000	+1.2			DATE					
2000 - 4000	±2.0			NAME					